

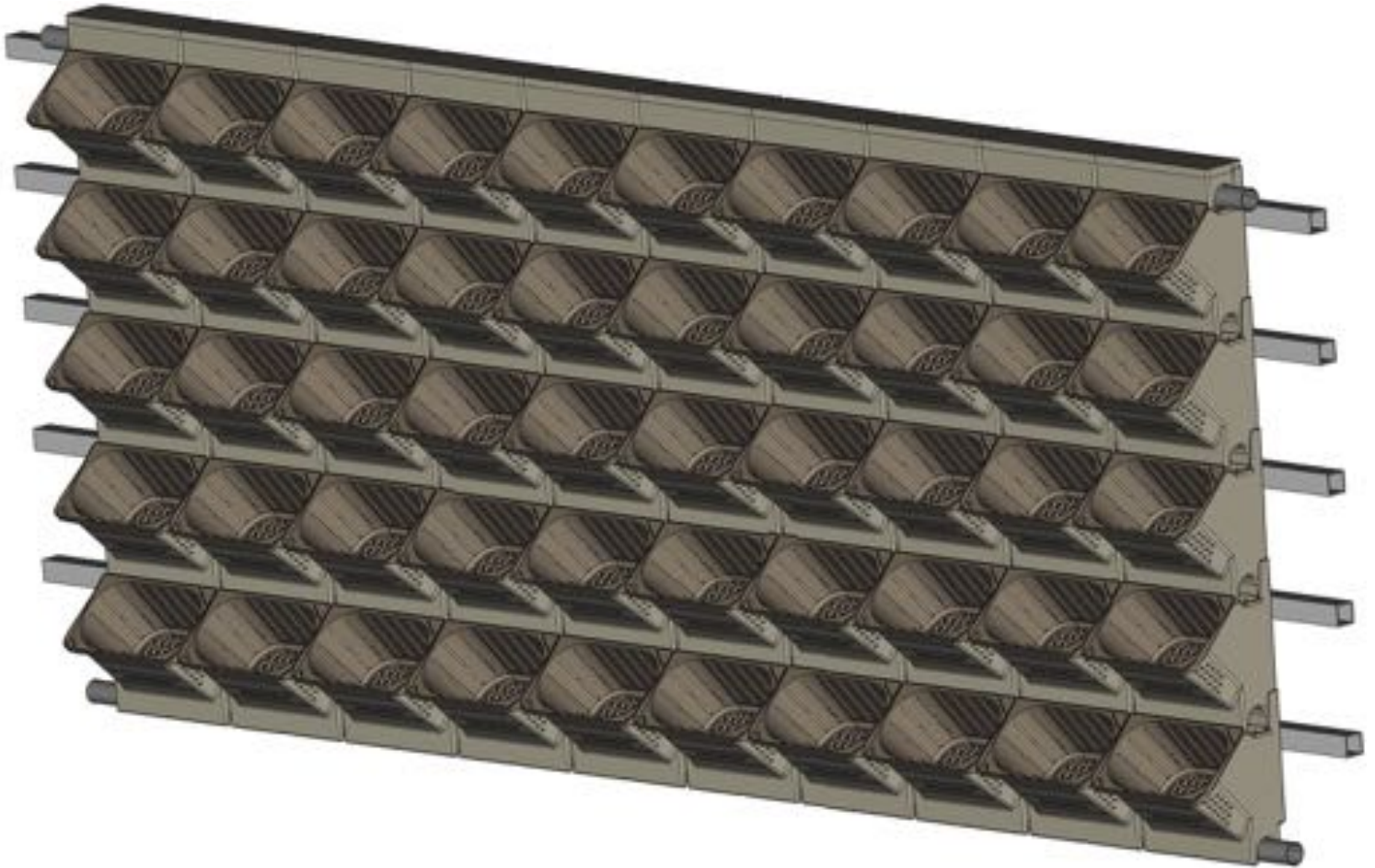

Info Sheet Wall System – Version: October 2021

Simple Example Installation:



Dimensions: 5 rows, 10 columns, width 2.1m, height 0.95m, ~2sqm covered.

Parts list:

- 50 Modules [A]
- 50 Pot Inserts [B]
- 10 Lids [C]

Required other parts:

- 3cm by 3cm mounting rails fixed already on the wall. Ideally holes for M5 screws are drilled as modules are mounted.
- 32mm/1" PVC pipe for irrigation 2.2m in top row. 20 drip emitters threaded into the pipe, 2 inside every module.
- 32mm/1" PVC pipe for drainage 2.2m in bottom row. 1 size smaller if joints and connections are needed.
- 100 Plants from 10.5cm diameter circular pots.
- 1-3 M5 mounting screws + nuts + 2 washers per module.

<https://www.aponix.eu/wall-system>



Info Sheet Wall System – Version: October 2021

Parts:

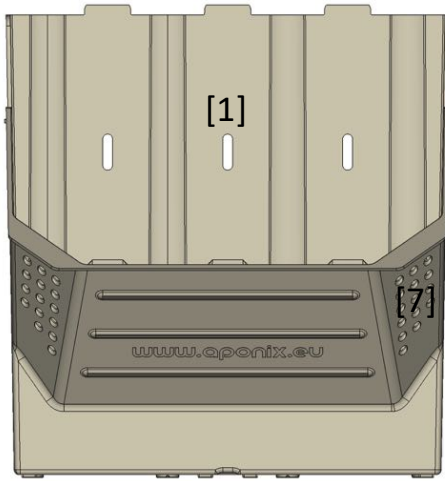

frontside

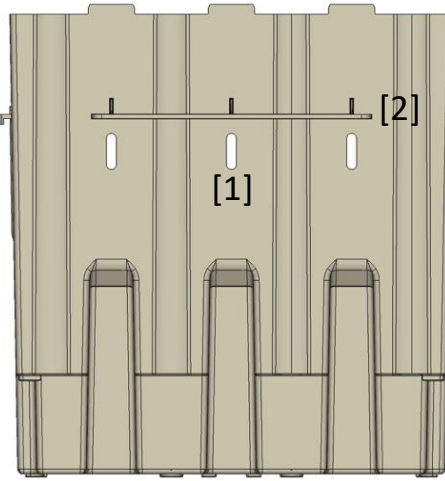

backside

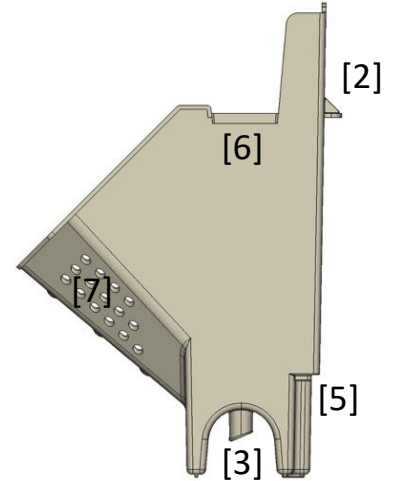

[A] Module

Materia: Flammability protected PP (V0) with UV stabilization. Raw material with certificate, within EU REACH directive safe to grow edibles.

Color:

- Module/Lid: RAL7023
- Pot Insert: RAL7006

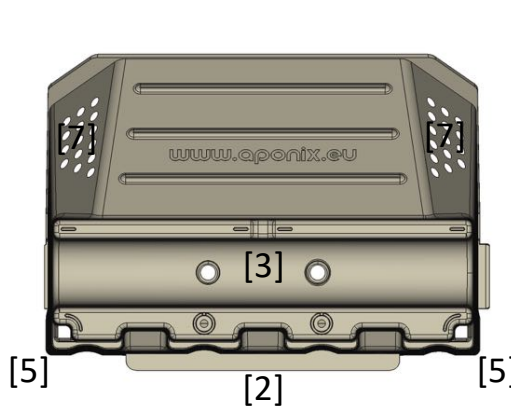

From underneath

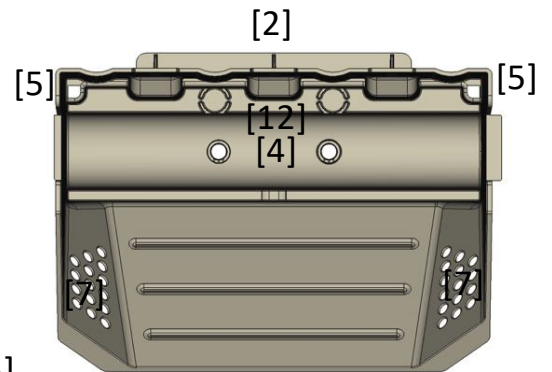

inside

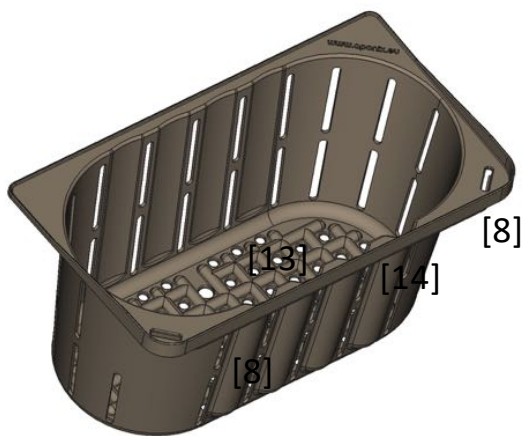

[B] Pot Insert

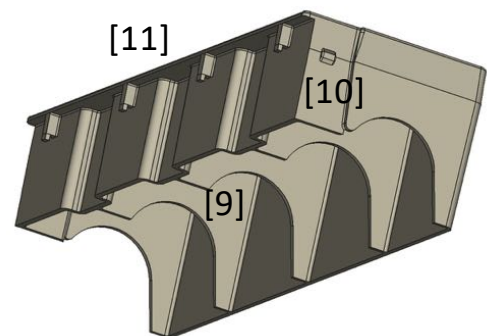

[C] Lid for top row



Info Sheet Wall System – Version: October 2021

Module installation planning:

Irrigation pipe required in first row: 32mm standard PVC with drip emitters for irrigation.



Draining pipe required in last row: 32mm standard PVC. Drainage through spikes [3].

Number and length of rows is flexible. Irrigation liquid fills reservoir in every module [A] hits inserted pot [B] through the two standard overflow pipes [4] and so forth until the liquid reaches the draining pipe underneath the bottom row.

It is possible to drain the liquid at a certain row in between rows of your wall and add fresh liquid from another irrigation pipe, see next page.

For the top most row (and all intermediate irrigation rows) the irrigation pipe is covered and fixed with the lid [C] part.

Dimensions of the ...

- Orange box: width 21cm, height 18cm.
- Red box: width 21cm, height including the top lid [C] 23cm.



Info Sheet Wall System – Version: October 2021

Multiple drainage and irrigation feeds:

In order to drain the liquid between your top and bottom row, you can do this by adding both pipes plus another row of lids [C] like this (see row with the red module):



Please note that the distance between rows increases when you add additional drainage and another irrigation line. See next page for metrics.

All irrigation and drainage piping and plumbing needs to be planned in advance including pump, reservoir fertigation if needed, addition of freshwater etc. We are using 32mm standard PVC pipes. Use one size smaller if you plan glued fittings in between. For the irrigation pipe you could also use any smaller diameter irrigation hose that you can equip well with robust drip emitters. For the draining pipe we recommend an inflexible 32mm/1" PVC pipe. It adds stability through the draining spikes [3].



Info Sheet Wall System – Version: October 2021

Mounting modules to a wall:

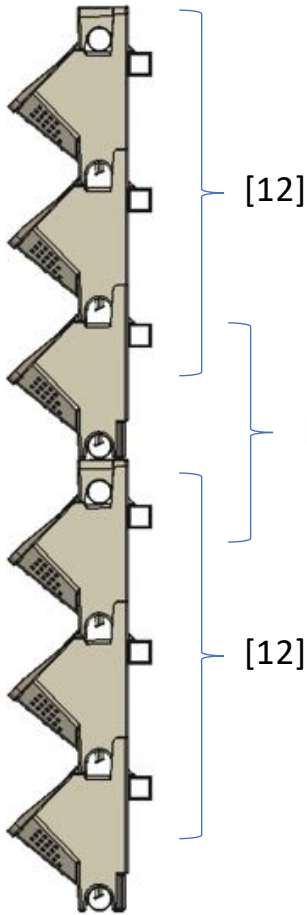

Mounting rails can be of any suitable material (metal or wood) and size. They need to provide a square edge and enough space to mount the modules [A] to your wall. The mounting rim [2] needs to be adjusted to your horizontal mounting rail. Adding a layer of vertical rails behind the horizontal ones will provide even better and vertical back ventilation.

Distance between the top of the mounting rails:

- [12] 18cm - If you stack rows when liquid flows from module to module.
- [13] 24cm - If you plan to install an additional draining and irrigation pipe in between rows (note the additional lid [C] and the additional pipe).

Distance between the holes in the draining pipe to fit the spikes [3]:

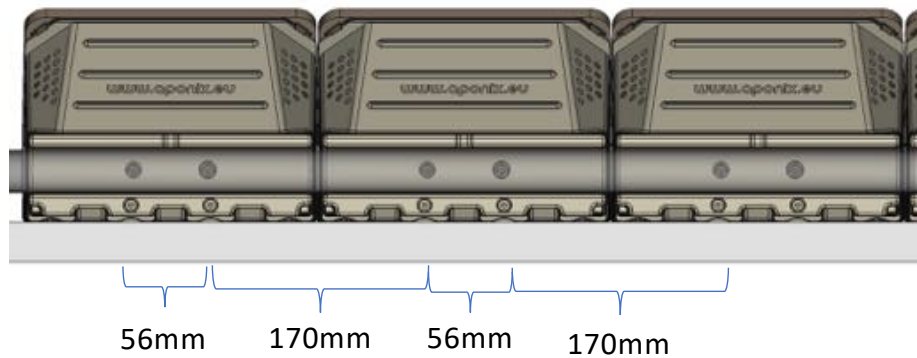

All spikes [3] have a diameter of 13mm. A hole diameter of 13-15mm is ideal. Please make sure all hole centers are aligned in a straight line on the pipe and drilled perpendicular.

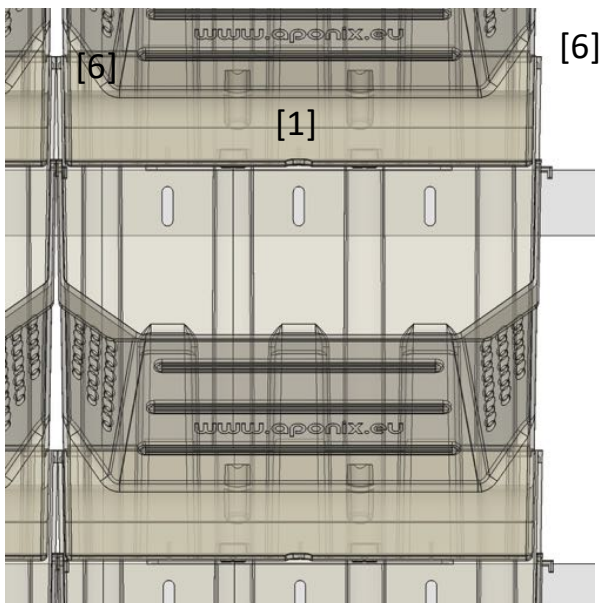

You screw the modules [A] to your prepared mounting rail [1]. Please start with the bottom most and right most module. Mount all modules row by row, from the bottom right to left each row after another.

- 1) If you are starting, please layout the first draining pipe and make sure it has all the required holes in the right spots for the spikes [3] in the modules to be inserted into these holes (distances of holes see above).
- 2) Put the module on top of the draining pipe (spikes [3] placed into the holes) and screw it to the mounting rail (with 1, 2 or 3 screws). Please use washers to protect the material.
- 3) Do so with all modules that are left of the one you started with.
- 4) Once you finished the row, start on the right side with the next row on top. Repeat step 4) for each row.



Info Sheet Wall System – Version: October 2021

Pot and overflow:

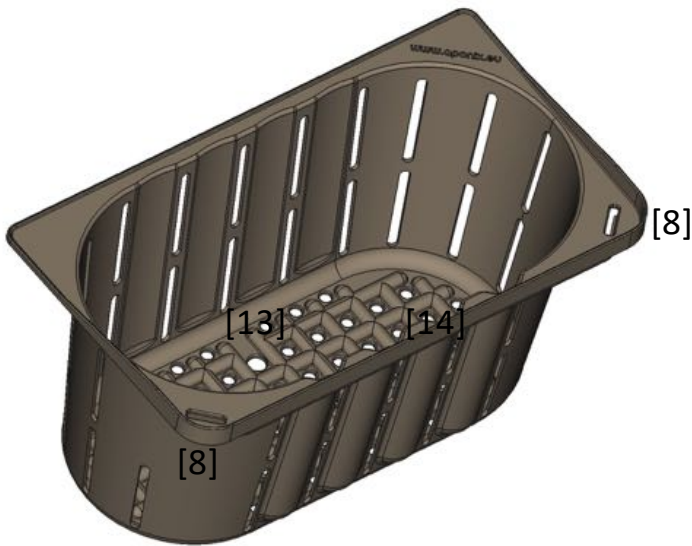

Pot dimensions from the top: 22cm by 12cm to fit two plants from a 10.5cm circular pot (fill the remaining gaps). Height seen from the side: 11cm.

Pots can be planted and prepared off-site on flood tables. A pot in a system can be replaced any time.

Substrate needs to be chosen and mixed according to the application. It is possible to use this WallSystem with a frequently irrigated hydroculture using hydroton pebbles.

The pot clicks into the module [A] when inserted using the 2 clickers [8] on the two front corners.

The pot has a higher rim in the front [14] to prevent storm water wash away your substrate.

There is one larger hole in the back of the base [13] in the pot that can be used to integrate a wicking fabric into the substrate if needed. It will hang into the reservoir area of the module.

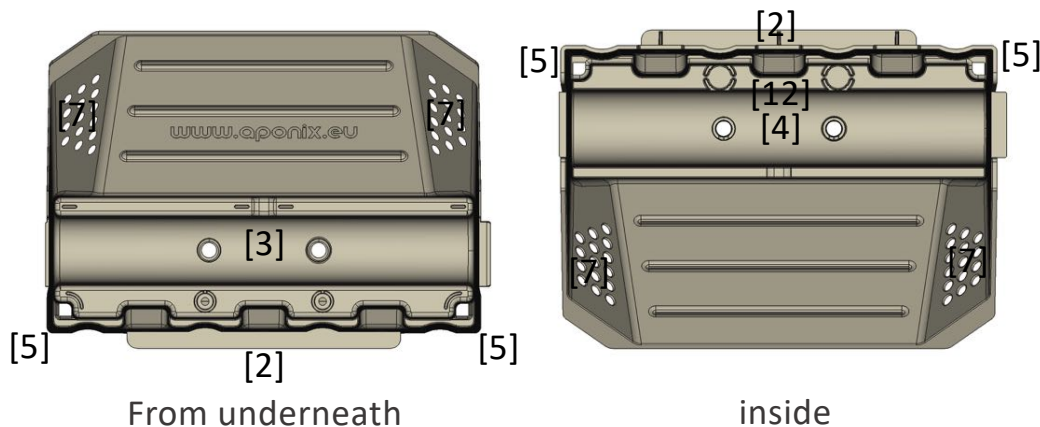

There are 2 optional draining inserts [12] that can optionally be created by drilling through with an 8/10mm drill from the outside. That way the setup would be for complete drainage (no more reservoir functionality). Please note that you can not use this in any rows where your plan is to drain the liquid and you have a draining pipe installed! After you drilled through these optional holes you need to prepare a 12mm PVC pipe with clean 90 degree cuts and additional holes along the length to accumulate liquid up to the height of this pipe but drain slower but completely. Max height is the height of the standard draining spikes [4] and the two emergency overflows in the corners [5]. This way the module prevents spillage out from the air holes in the front [7] in case of blockages.

Using the standard reservoir function you accumulate liquid up to the height of the standard draining spikes [4]. The water level in that case will be below the front edge of the fully inserted pot to keep your substrate drained and aerated all the time.