

MANUAL
Standalone soilless barrel

TABLE OF CONTENTS



Prerequisites to run a standalone soilless vertical barrel 2

 Required..... 3

 Recommended 4

 Height of the barrels and grow spaces..... 4

Scope of delivery 4

Assembly 7

 Step 1 - Mount fittings to standing base..... 7

 Step 2 - Assemble ring segments and stack them 8

 Step 3 - Put your submersible pump inside the reservoir and connect to buffer 9

 Step 4 - Fill your base with water and run the pump 11

Maintenance and cleaning..... 12

Materials used 12

 1/6 parts for ring segment assembly 12

 Lids and standing bases 12

MANUAL

Standalone soilless barrel

Prerequisites to run a standalone soilless vertical barrel

The standalone soilless vertical barrel can provide many soilless grow spaces on a very small footprint. The standard setup comes with a closed base, that serves as reservoir for a submersible pump and creates an internal circulation of the liquid irrigating through the top water buffer.

The closed base will serve as the reservoir for your liquid. Capacity is ~46 liters. There is an overflow that prevents over filling.

The liquid can be

- mineral fertilizer (hydroponics) or
- liquid from another alternative organic fertilizer source like fish in aquaponics.

In order to operate such a soilless setup successfully, you will need to make yourself familiar with the basic mechanics and procedures and also acquire the necessary utensils in order to be able to measure and operate the system. For hydroponics you will need to monitor and adjust a few parameters in order to generate a good yield from your plants. You will need an EC meter and a pH meter at minimum and of course other equipment to produce seedlings, the water soluble fertilizer, pH adjuster, 2-inch net pots, growing medium (e.g. rock wool), seeds etc. All this information is basic horticulture knowledge and can be found on the internet. Ideally you have a good friend that can help you ask the right questions if you are beginning to dive into soilless plant growing.

You will need to find a good spot for your soilless vertical barrel where plants can get sufficient sunlight, ventilation and can thrive in a suitable climate for your crop. That might be a balcony or terrace or ideally a greenhouse. If you plan to operate indoors you might need supplemental lighting too. Because the unit usually uses a submersible pump, you will need electricity to operate it.

We are planning to provide this metal base (see image below) that will fit well onto the bottom of the closed base. It will also allow to mount rolls to move the filled barrel around more easily.

MANUAL

Standalone soilless barrel

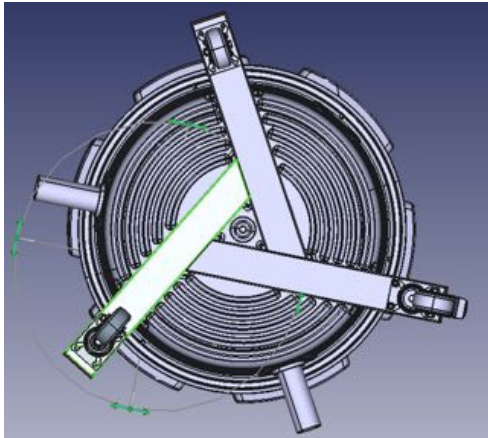

Required...

- Depending on the height of your barrel (is always a variable in aponix setups), you will need to get yourself a submersible aquarium pump. The max. flow rate of the water buffer that is filled by the pump is 2-3 liters per minute (not more). That is a pump that can just pump to the height of the barrel top plus a minor x. Usually that is a 20-30W pump you can also use for an aquarium. If you run too much water into the top water buffer, excess water will run through the overflow directly back into the reservoir. It makes sense not to overpower with the pump. If your pump is too powerful, you might want to add a valve in between the pump and the top buffer to fine tune the amount of water.
- You should run your pump on a timer depending on the substrate and amount of UV-radiation and heat. The idea is to prevent stress for your plants from drying and keep the medium moist. You could start with a twice an hour irrigation of 5/15mins and see how your plants are doing and adjust from there.
- You will need to test and maintain the liquid within certain ideal ranges. In hydroponics for leafy greens you try to keep these basic parameters:
 - EC: 0.9 to 1.5mS
 - pH: 5.8 to 7.0
 - Liquid temperature: 20 to 24C

There are many other parameters. If you are starting with hydroponics these ones are the ones you start with. In order to test for EC, pH and temperature you will need additional measuring equipment.
- Depending on the height of your barrel, you will need to get a hose of the length of the barrel height plus a bit extra. The size is dependent on the spigot on your pump. The usual tank connector is a 3/4 inch outside thread that you want to connect to. Most of the times this is included.
- Both ends of the hose should be tightened with a stainless steel clamp each.
- Please plan and get these missing parts before you start.

MANUAL

Standalone soilless barrel

Recommended

- Usually you need to insert pre-grown seedlings of the crops you like to grow soillessly. You can grow them yourself or buy them. Ideally you grow them yourself choosing a suitable medium and already grown them in the appropriate 2-inch net pots. That way the later transplantation into your soilless barrel is very fast and easy: You just insert the net pots with the seedlings into the grow spaces of your vertical barrel as you have space for them.
- A typical beginner mistake is to plant all grow spaces at once. If you are planning crops with different grow cycles that's fine.

Height of the barrels and grow spaces

One barrel has a diameter of 57cm on the outside surface. The number of grow spaces depends on the setup of your ring segments. You can increase grow space with the height of your barrel by just adding more ring segments. For larger plants you can use the closed spacer parts in your ring segments and stack your assembled ring segments accordingly. Each ring segment adds 15cm of height. The standing base has a height of ~20cm.

Scope of delivery

Depending on the configuration of your planned setup, these will be the parts that you will need for the assembly:

1/6th parts: closed (spacer) and ones with actual grow adapters in the form of net pot inserts.



Closed standing base – available with pre-

One ring segment is assembled using 6 of the 1/6th parts on the left. You can assemble as you plan your surface layout. Be creative!

Example: Alternating with spacer



Fittings for tanking L and overflow

MANUAL

Standalone soilless barrel

drilled holes or no additional holes



Special part: The revision piece:

When you assemble the lowest ring segment, do yourself a favor and add this part. By opening and closing the large cap it allows to reach inside a running barrel and pull out anything that might have fallen inside or reach for your pump.



The top irrigation water buffer is put on top of the topmost ring segment. It will be filled with water from the pump and irrigate through the 24 small holes on the inside by applying water to the inside wall of the barrel.

There is one elevated hole. This is the overflow. In case the pump delivers too much water, excess water just drops back into the reservoir. It might be noisy but better than a wet floor ;).

Please aim for not having to use this overflow! If you pump delivers too much water, you can always insert a valve



MANUAL

Standalone soilless barrel

between your pump and the water buffer to fine-tune the amount of water.

The black connection is supposed to be mounted into the 2nd hole in the center. This is where you connect your pump to fill the buffer.

There might be cases where there is no hole in the center. If you need it (for filling from below) you can always drill it yourself.

The version without this hole is the irrigation buffer that is filled from the top, usually the top lid by a sprinkler from which you removed the spinner, basically turning it into a micro tap.



The black part on the image on the right is a spigot with an inside thread to be threaded onto the centered connection on the water buffer. Please use your 2nd stainless steel clamp to tighten your hose to it.

Depending on the version this might be included or not. The standard spigot has a diameter for a 3/4 inch hose.



The top lid covers the water in the buffer.



MANUAL

Standalone soilless barrel

Assembly

Step 1 – Mount fittings to standing base

The small fitting is the overflow. It will drain excess liquid to the outside if the tank is completely filled.

The rubber sealing should seal the inside of the base. Let the long side stick outside the base so excess water does not run down and under the base itself.

In some setups this might be missing. Then it is up to the user not to overfill. It will give the user the possibility to use the full capacity of the base.



The larger fitting, is for the bigger hole. Mount the sealing from the inside. There is a slightly longer threaded side. Place it to the outside of the base and screw the L on it so it points upwards.

This is where you can tank / fill the water reservoir in the base top off with water.

In some setups this might be missing. In that case you will fill from the revision part or a grow space. Testing and adjusting EC, pH and temperature is best done through the revision opening!



MANUAL

Standalone soilless barrel

Info: All parts can also be purchased without pre-drilled holes, so you can decide where and how you organize drainage by drilling your own holes.

Each base has 3 flat areas that can be used to drill and attach other connections. For example if you are building a grey-water filter with this part.

If you need a larger hole you can always enlarge the existing holes with a file to fit your needs.



Step 2 – Assemble ring segments and stack them

Stack your planned ring segments. There are 4 possible positions between each level. The idea is to have the ideal position for your planned crop to grow and thrive.

Beginner mistake: If you plant too dense, your plants do not have the space to thrive and might have limited exposure to UV light and CO₂, and also are competing against each other for these resources.

Do not forget the lowest ring segment with the special revision part.



MANUAL

Standalone soilless barrel



Step 3 – Put your submergible pump inside the reservoir and connect to buffer

Mount your own submergible pump to a hose (both not included) and clamp the part with spigot and the inside thread to its end. This will be connected to the top irrigation buffer.

Ideally you have a long enough hose a) along the height of the barrel and b) to lift the connected water buffer conveniently.

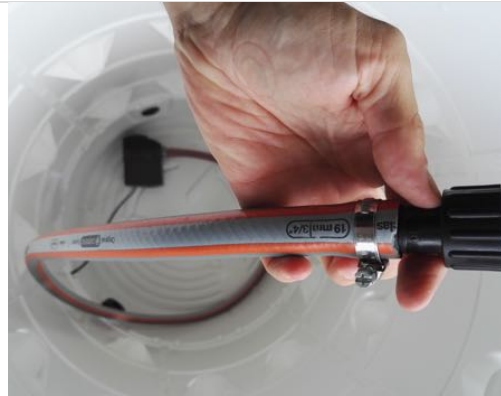

MANUAL

Standalone soilless barrel

In case you wonder, how and where the electricity cable should go, please use one of the dents around the bottom ring segment.

The purpose of the dents is, that it lets water that came to the outside of the barrel back into the reservoir instead of onto your floor. Water on the outside might appear in the form of droplets running downwards if you have wild leafy plants.



It looks like this once everything is connected.

Please note: You can lift the buffer part while it is connected to the submerged pump.

Put the buffer on the top ring segment now.

If you got the pre-assembled hose to connect to a pump from us, you will probably also have a valve for additional fine tuning. It might look like this:



MANUAL

Standalone soilless barrel

Step 4 – Fill your base with water and run the pump

Now you can fill the base, your reservoir with water.

Depending on the source of the water you might want to read up on what works best for your purpose. Topics: de-gase chlorine, use of rainwater, carbon hardness, pH.

Later this ‘water’ will be prepared as the nutrient solution – water plus the right amount of fertilizer maintained at ideal conditions and concentration during the growth cycle of your plants. If using liquid fertilizer in soilless growing systems this is new or unknown to you, please read up on it! If you only use water, your plants will not thrive and very soon show deficiencies.



Once you run your pump, the top buffer should slowly fill up.

Ideally you use a timer and fill the buffer as needed. The capacity is ~7 liters. Excess water runs back to the base through the overflow.

Once the buffer is filled, the duration for the irrigation is ~3mins. Please make sure to check if the 24 small irrigation holes do not get clogged over time and can do their job. Each grow space has 2 holes for irrigation.



MANUAL

Standalone soilless barrel

Once the liquid circulates from the reservoir through the inside of the barrel your grow spaces look like this – see the dripping on the backside. That is where the roots of your plant will be once you insert pre-grown seedlings in 2-inch net pots. There is an inside wing structure that directs the water on to the root area of your plants and ensures even irrigation regardless how high your barrel is and even if it is not straight but tilted a bit.



Maintenance and cleaning

From time to time you should harvest your vertical barrel completely, unstack the ring segments and power-wash the growing equipment to remove algae and pathogens. The materials are heavy duty commercial horticulture grade and we made it very hard for you to break them. You can use steam, pressure or light bleach or mix of that as with any other horticulture equipment too. The materials are thermoplastics! There are temperature and pressure limits of course. Very high pressure plus heat >80C will harm the surface of the material.

Materials used

All materials we use have been specifically certified as 'food-safe' by the raw material companies. In general the quality of the materials used are very similar if not the same even without explicit food grade certificate.

For more information on the materials used please see section 'Quality / Materials' on our webpage: <http://www.aponix.eu/vertical-barrel-soil-less/quality-and-usability/>

1/6 parts for ring segment assembly

As of January 2017 all 1/6th parts are made from ASA (Acrylester-Styrol-Acrylnitril).

Properties: Highest possible UV-resistant, Antistatic, dirt-repellent, long-living, inherently stable, shatter-proof, heat-resisting, having a stable color.

Lids, buffer and standing bases

PVC sheets vacuum molded. The raw materials used for the aponix parts come from trustworthy German providers who have to comply to very strict European rules (see: REACH directive / Verordnung (EG) Nr. 1907/2006 zur Registrierung, Bewertung, Zulassung und Beschränkung chemischer Stoffe). Raw material providers have

MANUAL

Standalone soilless barrel

confirmed their materials use tin and zinc instead of lead based stabilizers. We can provide more detailed information or original certificates if necessary.

Development status as of September 2017: The vertical barrel is in its first large series production, manufactured in Germany. We did our best to select the most durable and suitable materials available. The aponix.eu vertical barrel concept is patented.

