

MANUAL

Standing substrate based barrel

TABLE OF CONTENTS



Prerequisites to run one or many standing substrate based vertical barrels.....2

Required..... 2

Recommended 3

Height of the barrels and grow spaces..... 3

Irrigation..... 3

Scope of delivery3

Assembly5

Step 1 - Mount fittings to standing base..... 5

Step 2 - Filling the base..... 6

Step 3 - Stack ring segments on to the standing base and fill with substrate 8

Maintenance and cleaning..... 11

Materials used 12

1/6 parts for ring segment assembly12

Lids and standing bases12

MANUAL

Standing substrate based barrel

Prerequisites to run one or many standing substrate based vertical barrels

The substrate based vertical barrel can be operated like a raised bed but on a much smaller footprint. You will need to find a good spot for it where plants can get sufficient sunlight, ventilation and can thrive in a suitable climate for your crop. That might be a balcony or terrace.

Its primary use is outdoors. Working with soil and watering soil based planting systems can be messy if you do it in your living room. It may well be suitable for hallways, office space and semi-public spaces.

Please consider that a substrate based vertical barrel will be heavy once you filled it with substrate and watered it. You will not move it up or down stairs once it is up and running.

We are planning to provide this metal base that will fit well into the bottom of the closed base. It will also allow to mount rolls to move the filled barrel around more easily.

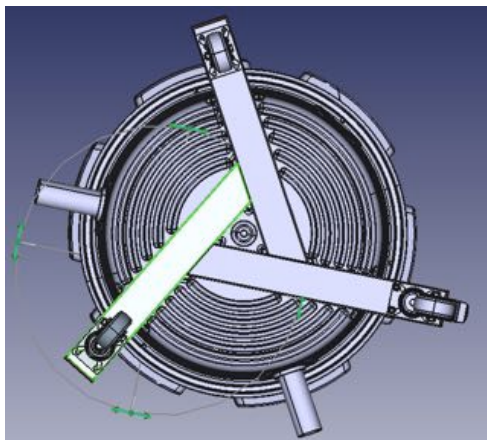

Required...

- The closed base will be filled with stones , lava rocks or hydroton. Later the base serves as water tank to irrigate by evaporation from the bottom. This is called wicking bed irrigation. The material you fill in here needs to be coarse but clean to prevent the weight from the soil on top to collapse into the area filled with water and at the same time provide enough capacity for water. You will need 50-60 liters of material to fill the base. How the base needs to be filled will be explained later on in more detail.

MANUAL

Standing substrate based barrel

- From the filled base and the top fabric layer you will start to set up ring segments of the barrel and fill them with your soil or substrate mix. It should be a light soil mix with sufficient nutrients or compost allowing for airflow and drainage. Each ring segment will be 15cm high and has a diameter of 57cm. You will need 50-60 liters of soil mix per ring segment you are planning to set up. You can change the number of ring segments later on any time.

Recommended

- A piece of inert fabric, the material that is put under pond liner to prevent punctures for example. But you could also use a piece of burlap. Size: 75cm by 75cm. This can be put into the closed base underneath the filling to protect the plastic.
- Another piece of the same or another lighter fabric (like shade cloth) can be used to cover the top of the closed base once it has been filled with stones. This is to prevent the soil to fall in between the rocks, mix with water or even touch standing water for a longer period. This will create problems for your plants. Size: 60cm by 60cm.

Height of the barrels and grow spaces

One barrel has a diameter of 66cm including the shelves on the outside surface. The number of grow spaces depends on the setup of your ring segments. You can increase grow space with the height of your barrel by just adding more ring segments. The top can also be planted with larger plants.

Irrigation

For small plants or seeding you will need to water the individual shelves gently by hand. Larger plants with bigger root systems can get their liquid from the inside that is wicking from the bottom water tank into the soil cylinder.

The closed base has an overflow valve. If your soil mix allows for sufficient drainage even if your barrel is standing in the rain the gravity and overflow valve in the closed base will drain excessive water.

Scope of delivery

Depending on the configuration of your planned setup, these will be the parts that you will need for the assembly:

1/6th parts: closed (spacer) and shelf	One ring segment is assembled using 6 of the 1/6th parts on the left. You can assemble as you plan your surface layout. Be creative!
--	--

MANUAL

Standing substrate based barrel

	<p>Examples:</p> 
<p>Closed standing base</p> 	<p>Fittings for tanking L and overflow</p> 

MANUAL

Standing substrate based barrel

Assembly

Step 1 – Mount fittings to standing base

The small fitting is the overflow. It will drain excess liquid to the outside if the tank is completely filled.

Standing water that touches the soil will cause problems and will serve as hotbed for pathogens.

The rubber sealing should seal the inside of the base. Let the long side stick outside the base so excess water does not run down and under the base itself.



The larger fitting, is for the bigger hole. Mount the sealing from the inside. There is a slightly longer threaded side. Place it to the outside of the base and screw the L on it so it points upwards.

This is where you can tank / fill the water reservoir in the base for wicking irrigation.



MANUAL

Standing substrate based barrel

Info: All parts can also be purchased without pre-drilled holes, so you can decide where and how you organize drainage.

Each base has 3 flat areas that can be used to drill and attach other connections. For example if you are building a grey-water filter with this part.

If you need a larger hole you can always enlarge the existing holes with a file to fit your needs.



Step 2 – Filling the base

You need 50-60 liters of cleaned and pH neutral lava rocks or hydroton to fill the base.

In order to protect the plastic base from damages you can insert a piece of inert fabric or burlap.



Please make sure you use pH-neutral material to fill the base. Limestone will not work. It will push pH too far up over time.



The material you fill into the base will probably need to be rinsed before you fill it into the base.

MANUAL

Standing substrate based barrel

	
<p>Put the optional fabric underneath and fill the base with the washed stones, pebbles or hydroton.</p> <p>In this case we used small lava rocks for the bottom and filled the rest up with lighter hydroton .</p> <p>You should fill the base at least until it is level with the overflow valve plus a bit more. This makes sure, the soil you put on top will never touch the water regardless how much water is remaining in the reservoir.</p>	
<p>The base will be already very heavy now. Ideally you now place it near its final destination and continue filling there.</p> <p>In this case, we assembled a simple wooden roller board.</p>	

MANUAL

Standing substrate based barrel

Step 3 – Stack ring segments on to the standing base and fill with substrate

Assemble your ring segments in the configuration you like to grow plants later.

The ring segments can be stacked in four different positions on top of each other.

If you plan crops with larger roots for the bottom, you could use 6 closed 1/6 pieces for the lowest ring segment.



Put your first ring segment into the base.

It makes sense to have another piece of inert fabric that does not block water to be put on top of the filled base. This will prevent the soil from falling into the gaps and touching water. It will separate the two distinct layers of material but also let water and water vapor through.

We used an old piece of shade cloth here.

Please check the section 'Required' for the amount of soil/substrate you will need to fill into your barrel.



MANUAL

Standing substrate based barrel

Start filling with your substrate pushing gently into the edges.

One thing we did here, since we had too much hydroton. We used a bucket to build a mold in the first substrate layer. We will later fill it with hydroton on order to have sort of an evaporation chimney.



This is the chimney being built into the inside of that barrel.



Once you filled the first ring segment and pushed enough substrate also into the corners of the shelf structures where your plants will sit, you can add the next ring segment and start filling that one.

You can repeat the bucket mold trick as often as you like.



MANUAL

Standing substrate based barrel

You are half way through the setup. Please get yourself a proper drink!



MANUAL

Standing substrate based barrel

Once you have filled your top ring segment, you can level out the top. This is a good space for your larger plants.



Water your barrel for the first time, so the substrate will sit properly.

Tank the base until the overflow starts draining.

Your standing substrate based barrel is now ready for planting!



Maintenance and cleaning

Usually there is not much to do besides planting, fertilizing and growing plants. If you like to disassemble or power-wash the equipment you can do that any time. Take care of

MANUAL

Standing substrate based barrel

your plants. The materials are heavy duty commercial horticulture grade and we made it very hard for you to break them.

From time to time you will need to add new compost or fertilizer. One method to reach the lower layers and at the same time aerate is to use a two long PVC pipes. One slightly smaller so it fits into the other one. Take the bigger pipe and use it like a syringe from the top. Fill the fertilizer into the pipe and push it through using the smaller pipe.

Materials used

All materials we use have been specifically certified as 'food-safe' by the raw material companies. In general the quality of the materials used are very similar if not the same even without explicit food grade certificate.

For more information on the materials used please see section 'Quality / Materials' on our webpage: <http://www.aponix.eu/vertical-barrel-soil-less/quality-and-usability/>

1/6 parts for ring segment assembly

As of January 2017 all 1/6th parts are made from ASA (Acrylester-Styrol-Acrylnitril).

Properties: Highest possible UV-resistant, Antistatic, dirt-repellent, long-living, inherently stable, shatter-proof, heat-resisting, having a stable color.

Lids and standing bases

PVC sheets vacuum molded. The raw materials used for the aponix parts come from trustworthy German providers who have to comply to very strict European rules (see: REACH directive / Verordnung (EG) Nr. 1907/2006 zur Registrierung, Bewertung, Zulassung und Beschränkung chemischer Stoffe). Raw material providers have confirmed their materials use tin and zinc instead of lead based stabilizers. We can provide more detailed information or original certificates if necessary.

Development status as of September 2017: The vertical barrel is in its first large series production, manufactured in Germany. We did our best to select the most durable and suitable materials available. The aponix.eu vertical barrel concept is patented.